

**INDUSTRIAL X-RAY TUBE
E7690**

X-ray Tube for Industrial Use

- ◆ The X-ray tube E7690, which has focus 1.0×1.0 is designed for non-destructive X-ray inspection.
- ◆ This tube can be used with Max. 75 kV constant potential circuit of cathode grounded.



General Data

Electrical:

Circuit:

High Voltage Generator Constant potential high-voltage generator
 Grounding Cathode and X-Ray port grounded
 Nominal X-ray Tube Voltage 75 kV
 Nominal Focal Spot Value (*) 1.0×1.0

(*) Permissible Value: Refer to IEC60336:1982.

Mechanical:

Dimensions See dimensional Outline
 Overall Length 185 mm
 Maximum Diameter $\phi 62$ mm
 Target:
 Angle 20 degrees
 Material Tungsten
 Inherent Filtration Be 1.0 mm
 X-ray Coverage (Angle):
 Tube Axis Direction 30 degrees
 Normal to Tube Axis Direction 45 degrees
 Weight (Approx.) 1000 g
 Insulating Medium Insulation Oil
 Cooling Method Oil immersed (60°C Max.) and convection oil cooling.
 Tube Holding Holding the mounting flange with 6-M4 screws

★The information contained herein is presented only as a guide for the application of our products. No responsibility is assumed by Canon Electron Tubes & Devices Co., Ltd. (CETD) for any infringements of patents or other rights of the third parties which may result from its use. No license is granted by implication or otherwise under any patent or patent rights of CETD or others.
 ★The information contained herein may be changed without prior notice. It is therefore, advisable to contact to CETD before processing with the design of equipment incorporating this product.

Absolute Maximum and Minimum Ratings
(At any time, these values must not be exceeded.)

Maximum X-ray Tube Voltage	75 kV
Minimum X-ray Tube Voltage	20 kV
Maximum X-ray Tube Current	8 mA
Maximum Filament Current	3.9 A
Filament Frequency Limit	DC or AC (Sine Wave) 0 ~ 20 kHz
Maximum Input Energy (Continuously)	350 W

Environmental Limits

Operating Limits (in dielectric oil):

Oil Temperature 10 ~ 60 °C

Oil pressure 70 ~ 140 kPa

Shipping and Storage Limits:

Temperature -40 ~ 70 °C

Humidity 10 ~ 90 %

(No condensation)

Atmospheric Pressure 50 ~ 106 kPa

Emission & Filament Characteristics

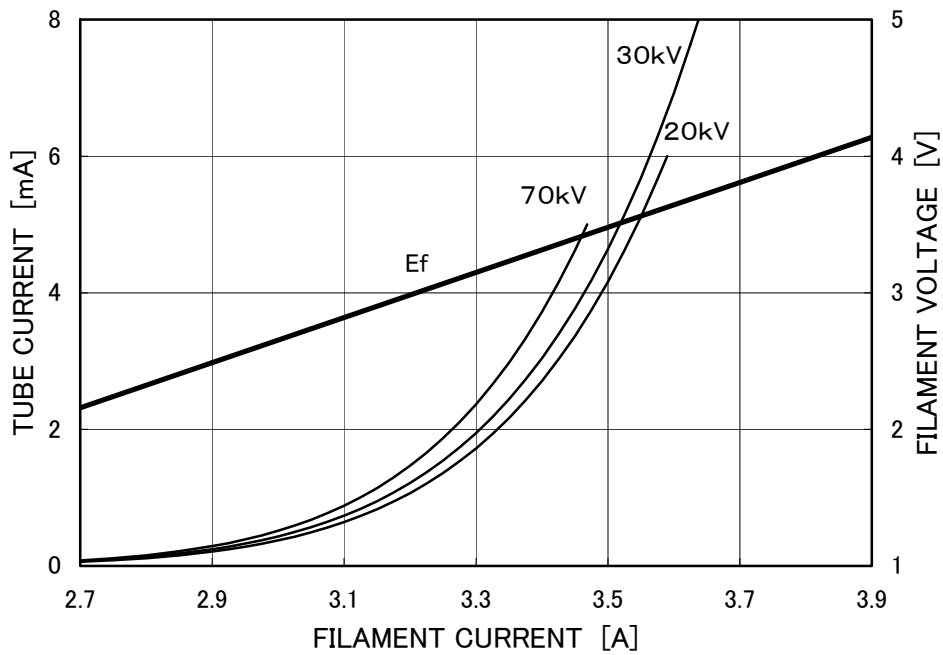

Note: This graph indicate typical characteristics.

Maximum Input (continuous)

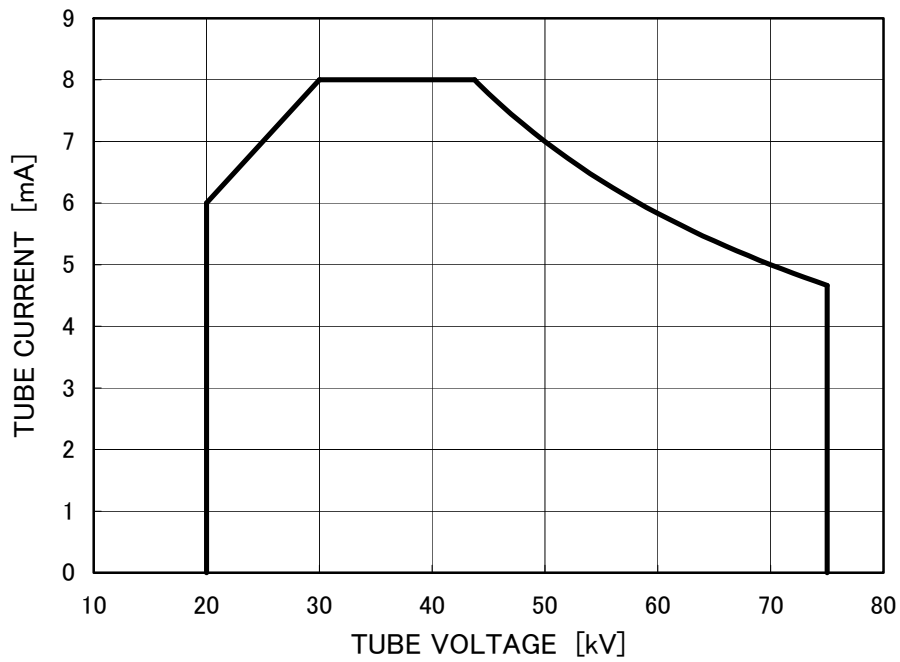

Dimensional Outline

Unit: mm

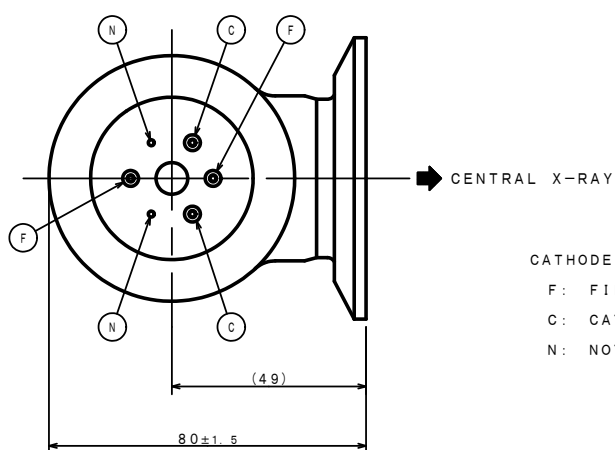
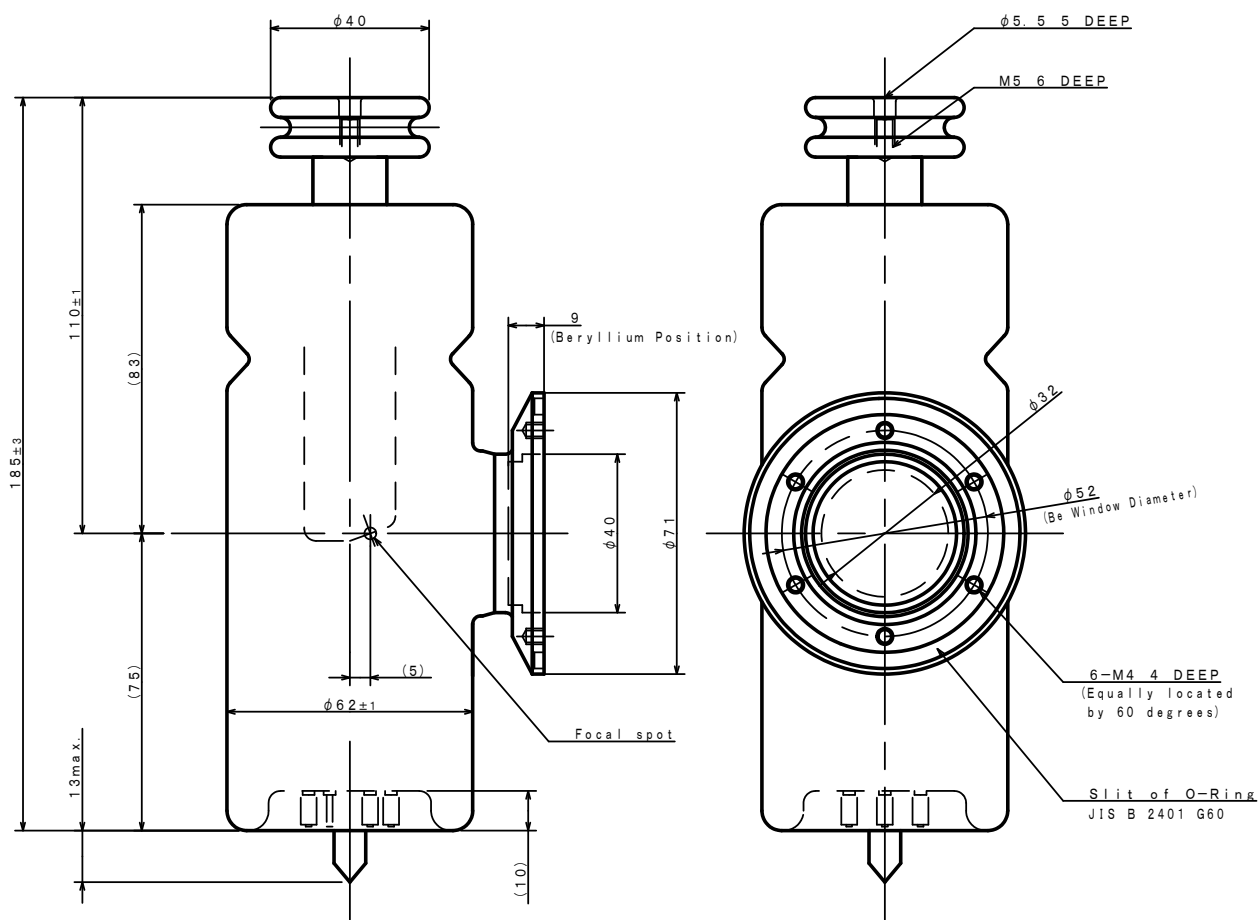



CANON ELECTRON TUBES & DEVICES CO., LTD.

Marketing Engineering Group, Sales Department
1385, Shimoishigami, Otawara-shi, Tochigi 324-8550, Japan
Tel: +81-287-26-6666 Fax: +81-287-26-6060
<https://etd.canon>

·The head office of Canon Electron Tubes & Devices Co., Ltd. has been certified to meet all the requirements of Environmental Management System ISO14001.
·Canon Electron Tubes & Devices Co., Ltd. has been certified to meet all the requirements of Quality Management Systems ISO9001 and ISO13485.
Product scope is referred to the following URL. <https://etd.canon/eng/company/quality.htm>.