

**ROTANODE™
E79016X**

Rotating Anode X-ray Tube Assembly

- ◆ The rotating anode X-ray tube assembly E79016X is designed with Hydrodynamic bearing lubricated by liquid metal and its rotor offers continuous high speed, extra low noise and high reliability.
- ◆ This tube has the grid control function, which is capable of high-speed pulse-fluoroscopy suitable for high speed such as cine- fluoroscopy.
- ◆ It performs high cooling rate 3.5kW and high patient throughput with the featuring of 2130kJ anode heat capacity and water cooling heat exchanger.

General Data

IEC Classification (IEC60601-1:2005+A1:2012) Class I ME EQUIPMENT

Electrical:

Circuit:

High Voltage Generator Constant Potential High-voltage Generator

Grounding Center-grounded

Nominal X-ray Tube Voltage:

Radiographic 125 kV

Fluoroscopic:

Continuous 125 kV

Grid-Control 120 kV

Nominal Focal Spot Value:

Large Focus 1.0

Middle Focus 0.6

Small Focus 0.3

Nominal Anode Input Power (at 0.1s) See rating charts

Large Focus 100 kW

Middle Focus 48 kW

Small Focus 17 kW

Nominal Radiographic Anode Input Power:

Large Focus 96 kW

Middle Focus 46 kW

Small Focus 16 kW

★The information contained herein is presented only as a guide for the application of our products. No responsibility is assumed by Canon Electron Tubes & Devices Co., Ltd. (CETD) for any infringements of patents or other rights of the third parties which may result from its use. No license is granted by implication or otherwise under any patent or patent rights of CETD or others.

★The information contained herein may be changed without prior notice. It is therefore, advisable to contact to CETD before processing with the design of equipment incorporating this product.

Anode Speed	Minimum 9000 min ⁻¹
Cut-off Grid Voltage (Small Focus)	-2900 VDC
Resistance between Housing and Low Voltage Terminals	Minimum 2 MΩ
	(Measured by DC 500 V)
Heat Exchanger Input Voltage / Input Current	AC 100V, 2A
Heat Exchanger Source Frequency	50/60 Hz
Normal Operating Range of the Housing Temperature	16 ~ 75 °C
Mode of Operation	Intermittent
Envelope Current (125kV/100mA)	(Approx) 10 mA
Envelope Voltage (125kV/100mA)	0 kV

Mechanical:

Dimensions	See dimensional outline
Overall Length	562 mm
Maximum Diameter	213 mm
Target:	
Anode Angle (Effective)	11 degrees
Diameter	140 mm
Construction	Rhenium-Tungsten faced Molybdenum
Permanent Filtration	1.1 mm Al / 75 kV IEC60522:1999
Radiation Protection (In accordance with IEC60601-1-3:2008):	
X-ray Leakage	0.44 mGy/h
Leakage Technique Factor	125 kV, 18 mA
X-ray Coverage	389 × 521 mm at SID 1000 mm
Weight (Approx.)	46 kg
High Voltage Receptacle	CLAYMOUNT MINI-75
Cooling Method	Water-Cooled Heat Exchanger
Inner Cooling Method	Oil Circulation
Tube Model Number	DSR-T7345G,U
Tube Housing Model Number	XH-177

Absolute Maximum and Minimum Ratings (At any time, these values must not be exceeded.)

Maximum X-ray Tube Voltage:	
Radiographic	125 kV
Fluoroscopic:	
Continuous	125 kV
Grid-control	120 kV
Between Anode (or Cathode) and Ground	62.5 kV
Minimum X-ray Tube Voltage	50 kV
Maximum X-ray Tube Current	See rating charts
Large Focus (1.0)	1100 mA
Middle Focus (0.6)	650 mA
Small Focus (0.3)	180 mA
Maximum Filament Current:	
Large Focus (1.0)	5.9 A
Middle Focus (0.6)	5.2 A
Small Focus (0.3)	5.4 A
Filament Voltage: (At maximum filament current)	
Large Focus (5.9 A)	12.5 ~ 16.7 V
Middle Focus (5.2 A)	10.0 ~ 13.4 V
Small Focus (5.4 A)	3.7 ~ 5.0 V
Filament Frequency Limits	0 ~ 25 kHz
Continuous Anode Input Power	2200 W (3100 HU/s)
20 minutes	3000 W (4230 HU/s)
Thermal Characteristics:	
Anode Heat Content	2130 kJ (3000 kHU)
Maximum Anode Heat Dissipation	5500 W (7700 HU/s)
X-ray Tube Assembly Heat Content	2050 kJ (2890 kHU)
Nominal Continuous Input Power:	
With Water-Cooling Heat Exchanger (HEX-125 or HEX-119)	3500 W (296 kHU/min)

Environmental Limits

Operating Limits:	
Temperature	18 ~ 40 °C
Relative Humidity	30 ~ 85 %
	(No condensation)
Atmospheric Pressure	70 ~ 106 kPa
Transport and Storage:	
Temperature:	
With cooling water empty	-20 ~ 70 °C
With cooling water filled	2 ~ 60 °C
Relative Humidity	20 ~ 90 %
	(No condensation)
Atmospheric Pressure	50 ~ 106 kPa

Absolute Maximum Rating Charts (Single Load Rating Charts)

Conditions: Constant Potential High- voltage Generator
Anode Rotation Speed 9000min⁻¹

Nominal Focal Spot Value: 1.0 ■

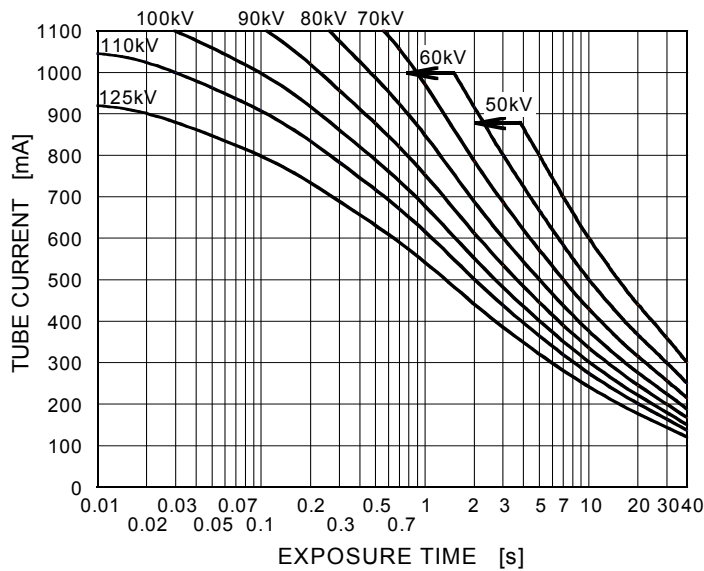

Do not exceed values in above table at all the time.
Equipment setting and calibration errors must be considered not to exceed the table values.

Nominal Focal Spot Value: 0.6 ■

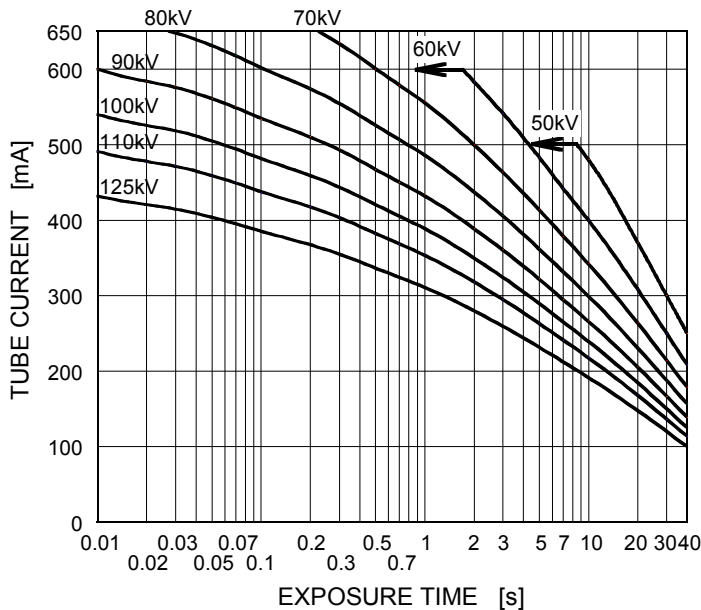

Do not exceed values in above table at all the time.
Equipment setting and calibration errors must be considered not to exceed the table values.

Absolute Maximum Rating Charts (Single Load Rating Charts)

Conditions: Constant Potential High-voltage Generator
Anode Rotation Speed 9000min^{-1}

Nominal Focal Spot Value: 0.3 \square

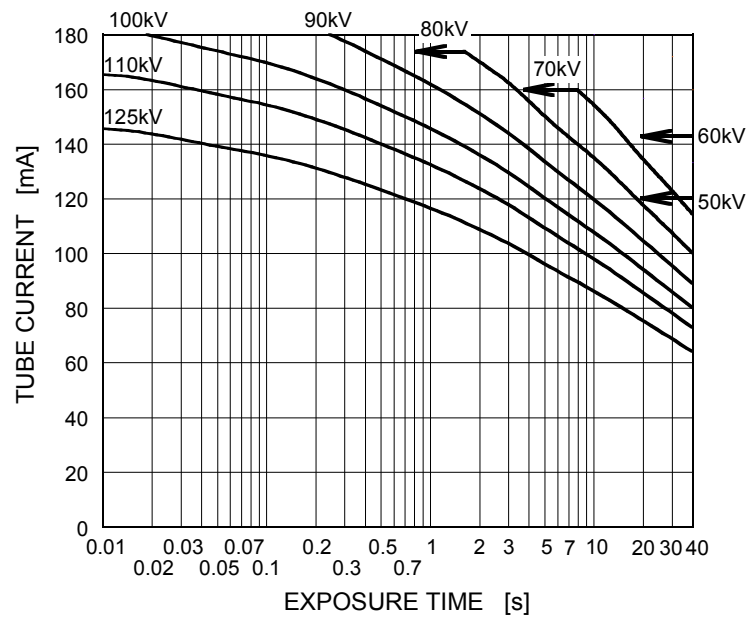

Do not exceed values in above table at all the time.

Equipment setting and calibration errors must be considered not to exceed the table values.

Cine-fluorographic Rating Charts

Conditions: Constant Potential High-voltage Generator
 Anode Rotation Speed 9000min⁻¹

Nominal Focal Spot Value: 1.0 ■

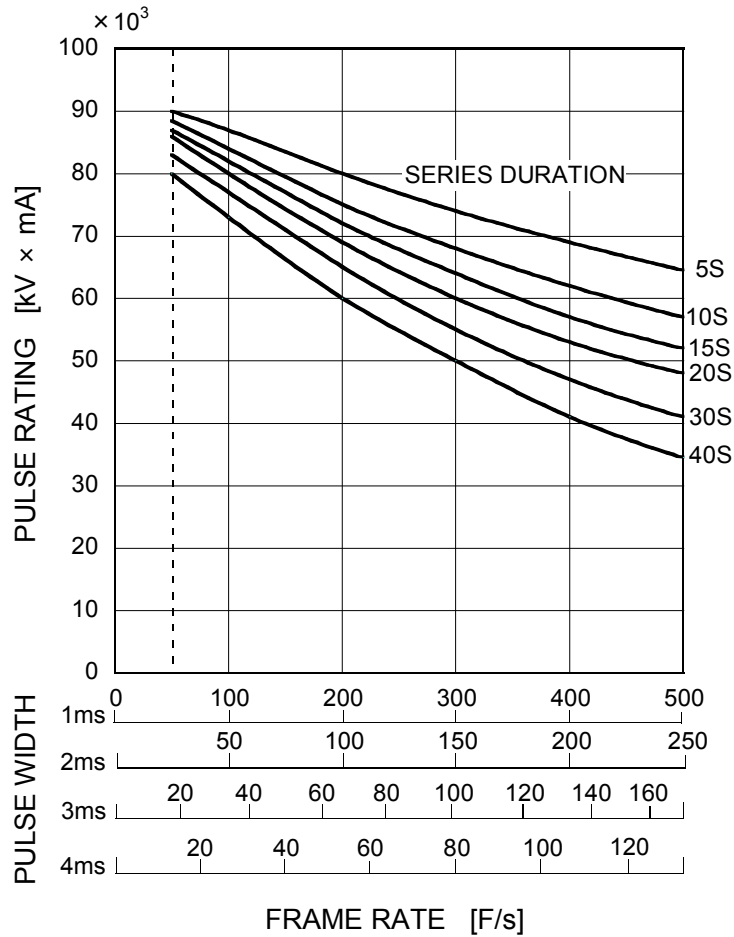

Do not exceed values in above table at all the time.
 Equipment setting and calibration errors must be considered not to exceed the table values.

Cine-fluorographic Rating Charts

Conditions: Constant Potential High-voltage Generator
Anode Rotation Speed 9000min^{-1}

Nominal Focal Spot Value: 0.6 mm^2

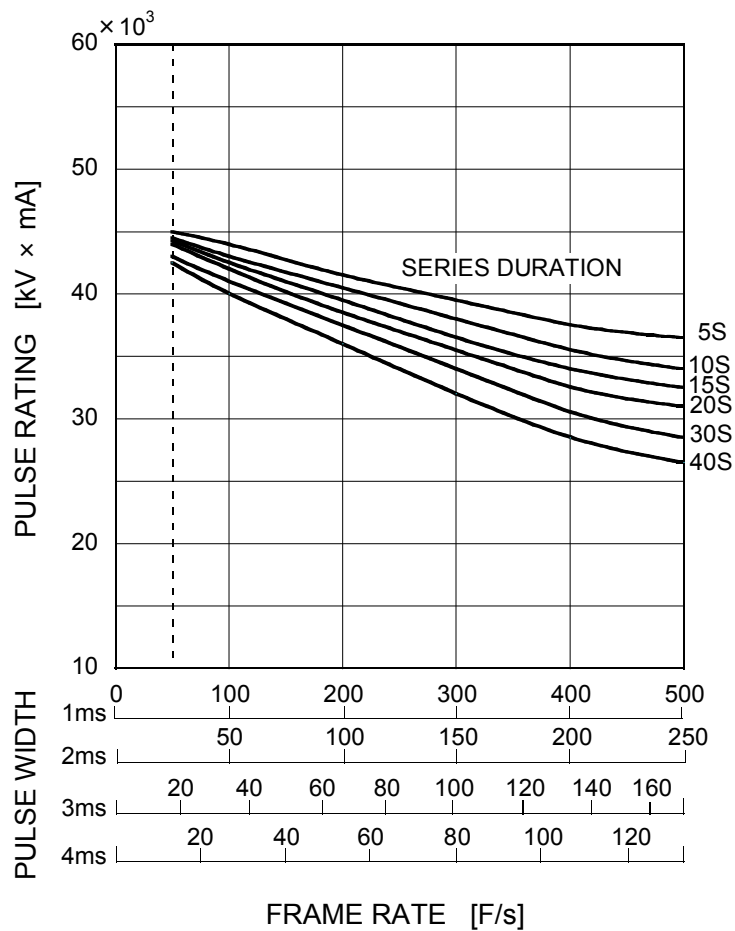

Do not exceed values in above table at all the time.
Equipment setting and calibration errors must be considered not to exceed the table values.

Angiographic Rating Charts

Conditions: Constant Potential High-voltage Generator
 Anode Rotation Speed 9000min⁻¹

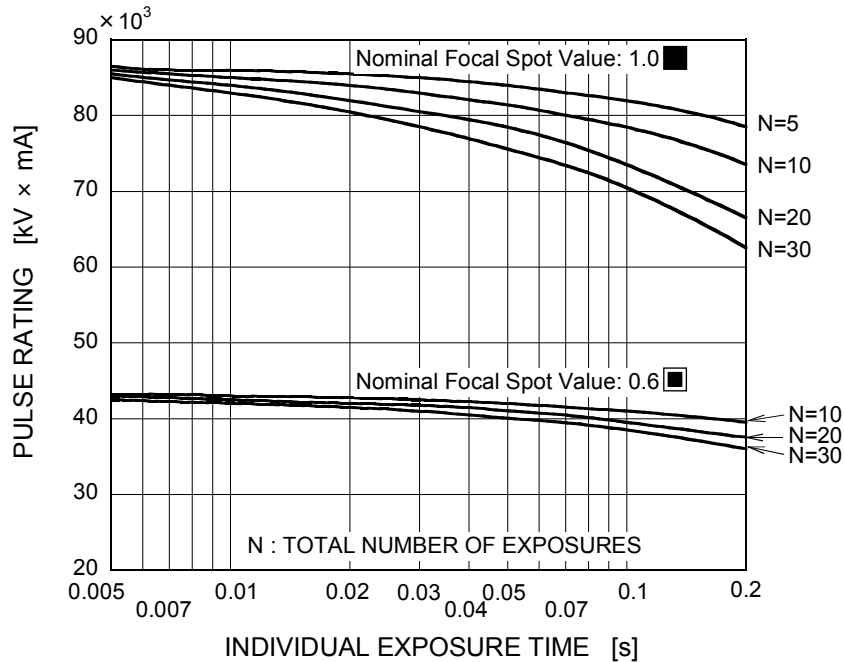

Do not exceed values in above table at all the time.
 Equipment setting and calibration errors must be considered not to exceed the table values.

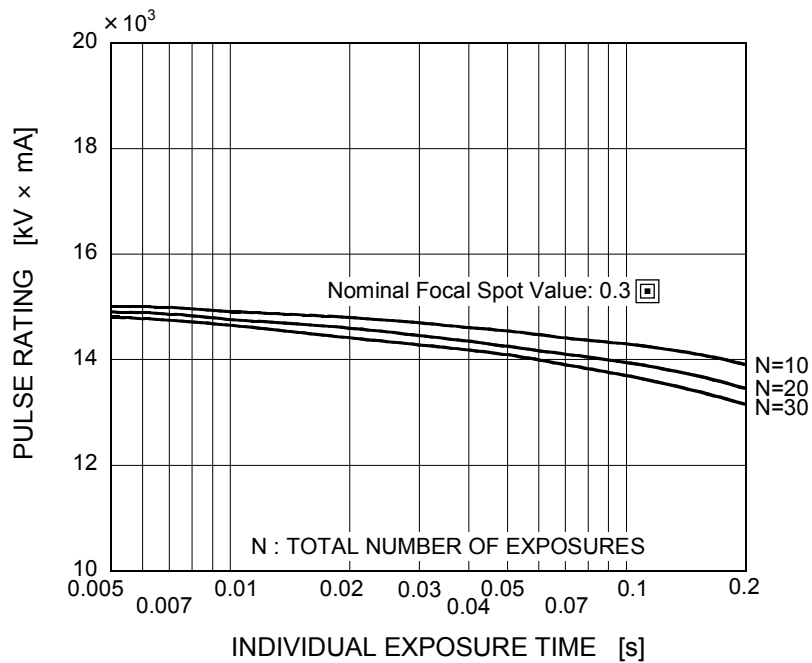

Do not exceed values in above table at all the time.
 Equipment setting and calibration errors must be considered not to exceed the table values.

Emission & Filament Characteristics

Constant Potential High-voltage Generator

Nominal Focal Spot Value: 1.0 ■

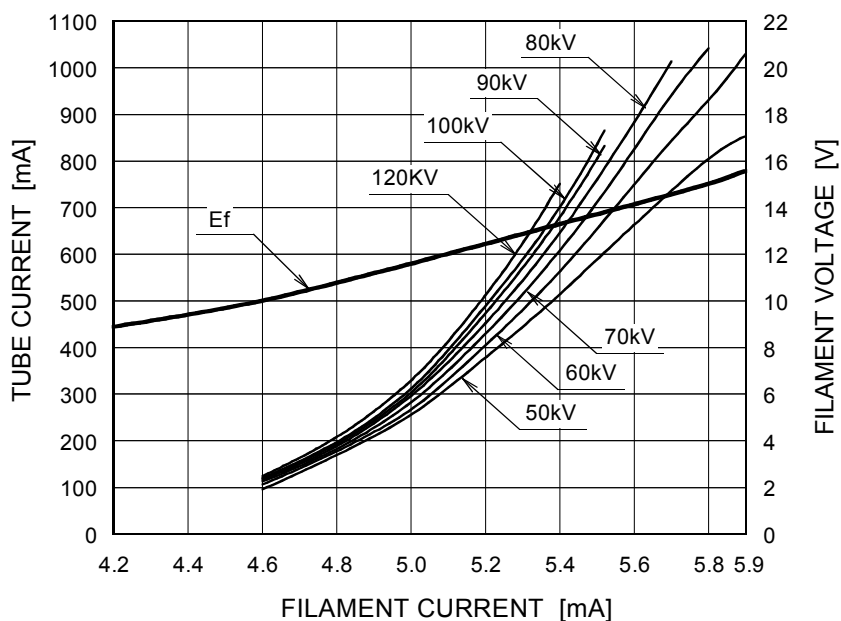

For Reference Only

Nominal Focal Spot Value: 0.6 ■

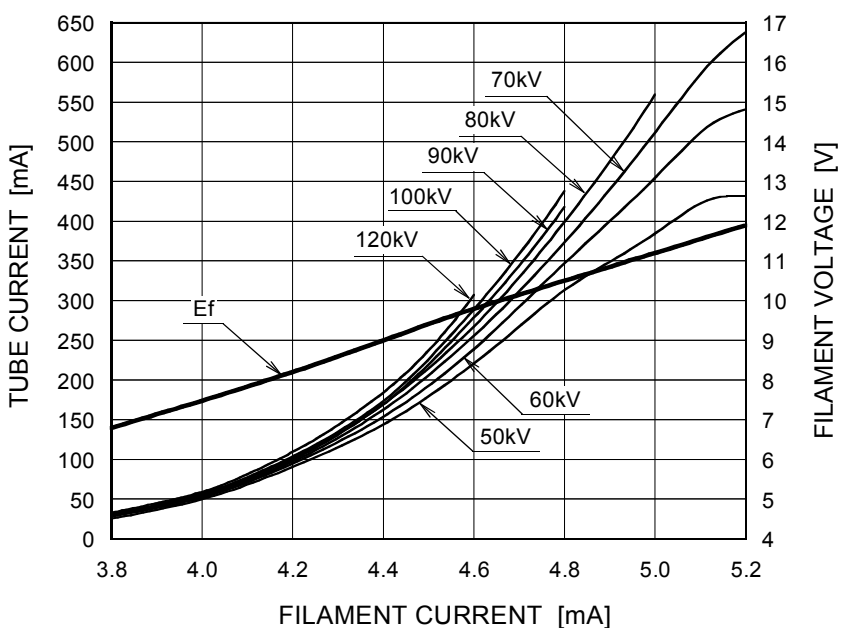

For Reference Only

Emission & Filament Characteristics

Constant Potential High-voltage Generator

Nominal Focal Spot Value: 0.3 \square

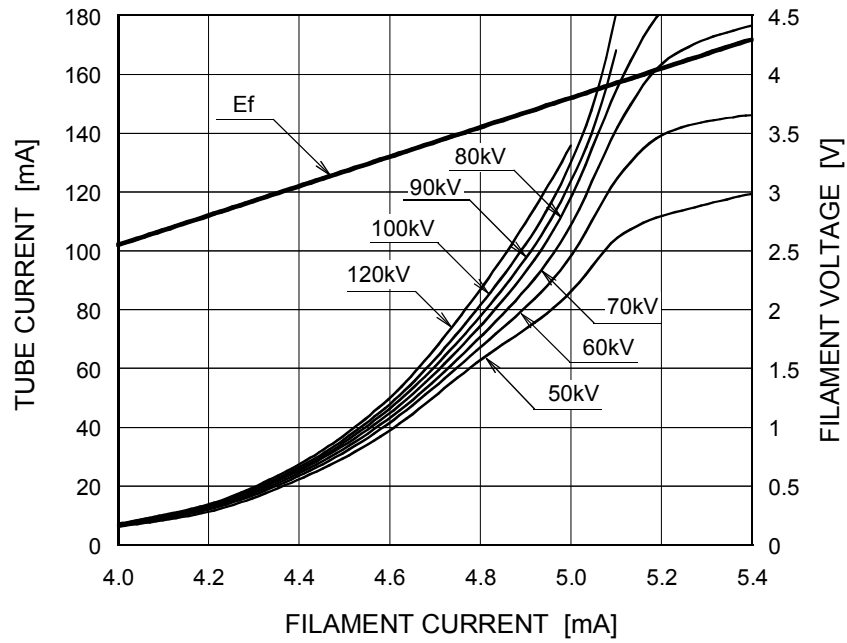

For Reference Only

Thermal Characteristics

X-ray Tube Assembly Heating / Cooling Curve
(Environmental Temperature : 25°C)

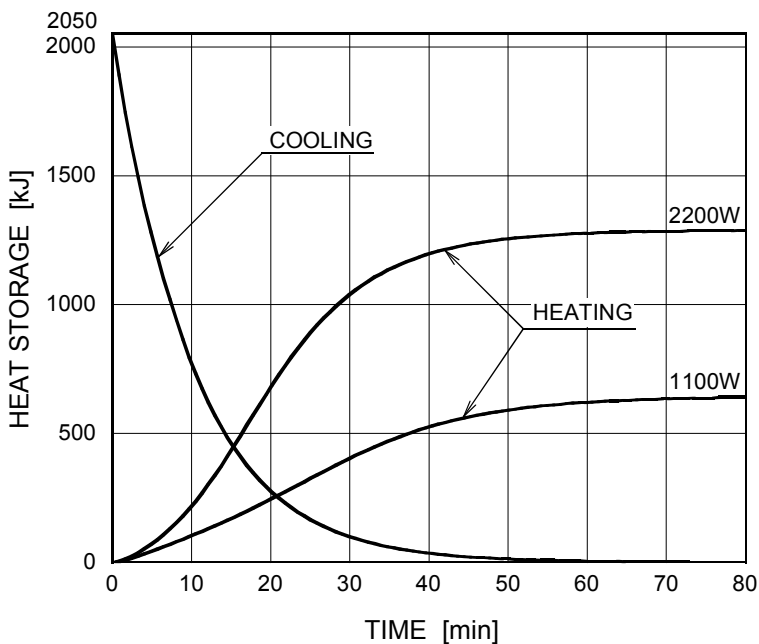

Anode Heating / Cooling Curve

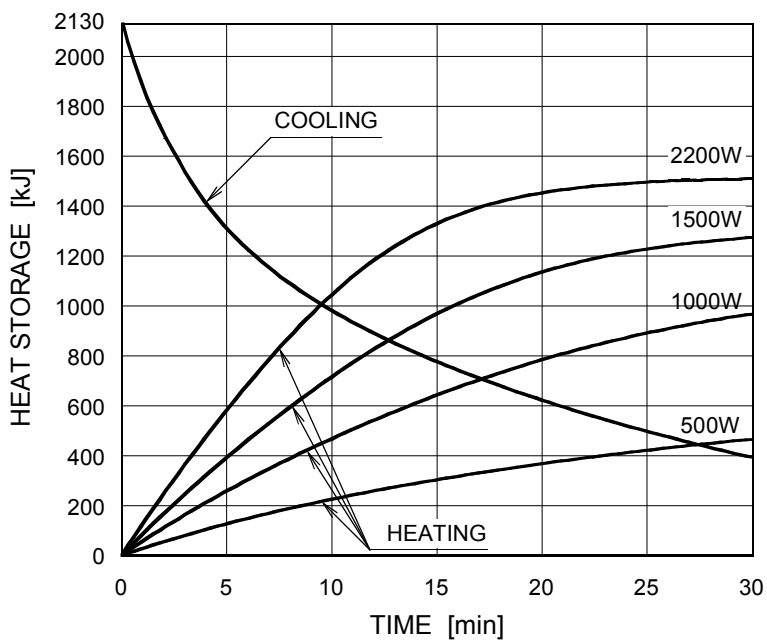

Dimensional Outline (1)

Unit: mm

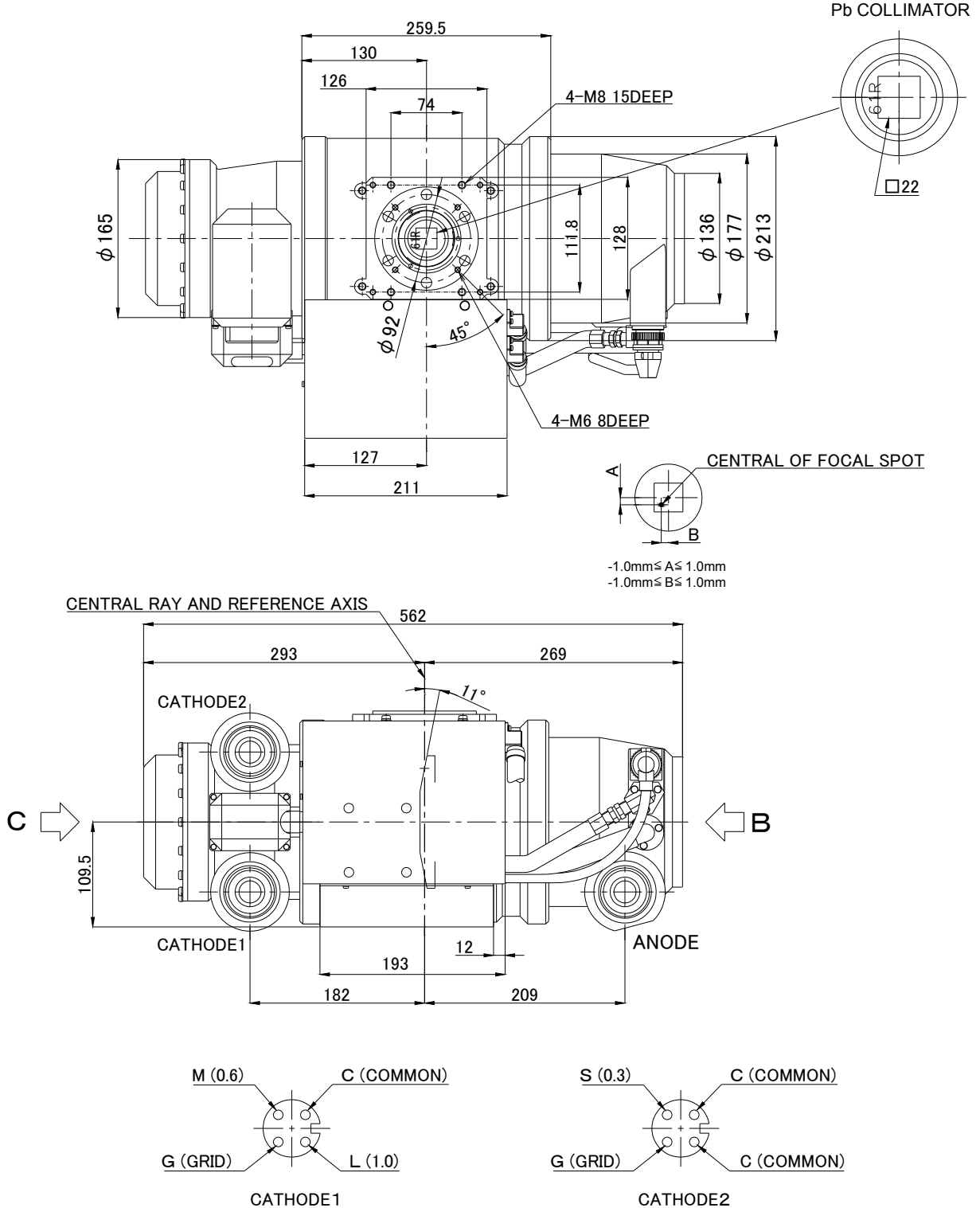

ANODE & CATHODE TERMINAL: CLAYMOUNT MINI-75

Dimensional Outline (2)

Unit: mm

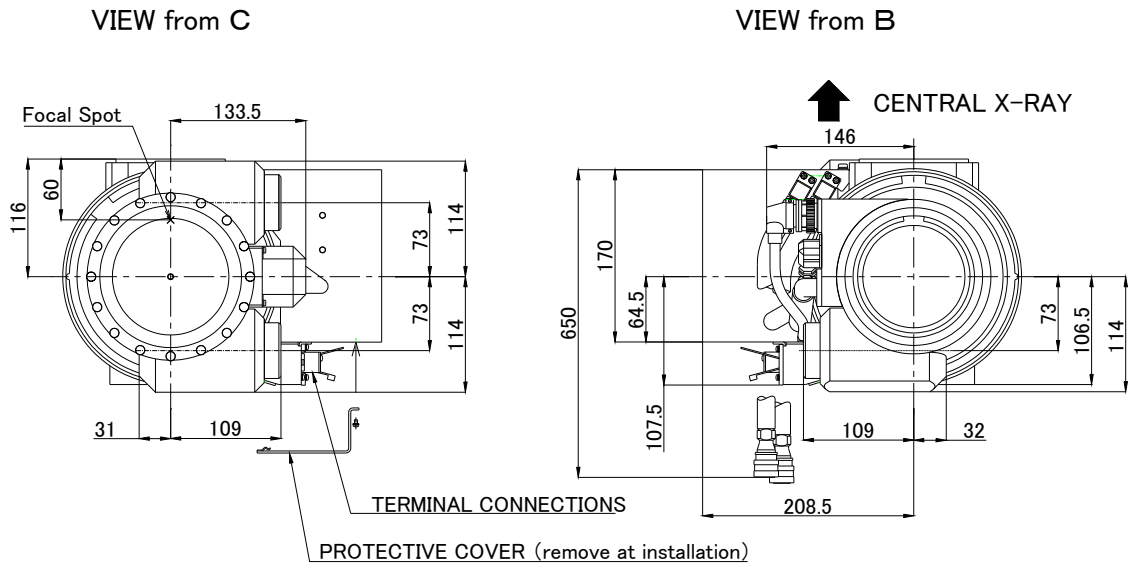

LOW VOLTAGE WIRING DIAGRAM PORT TERMINAL CONFIGURATION

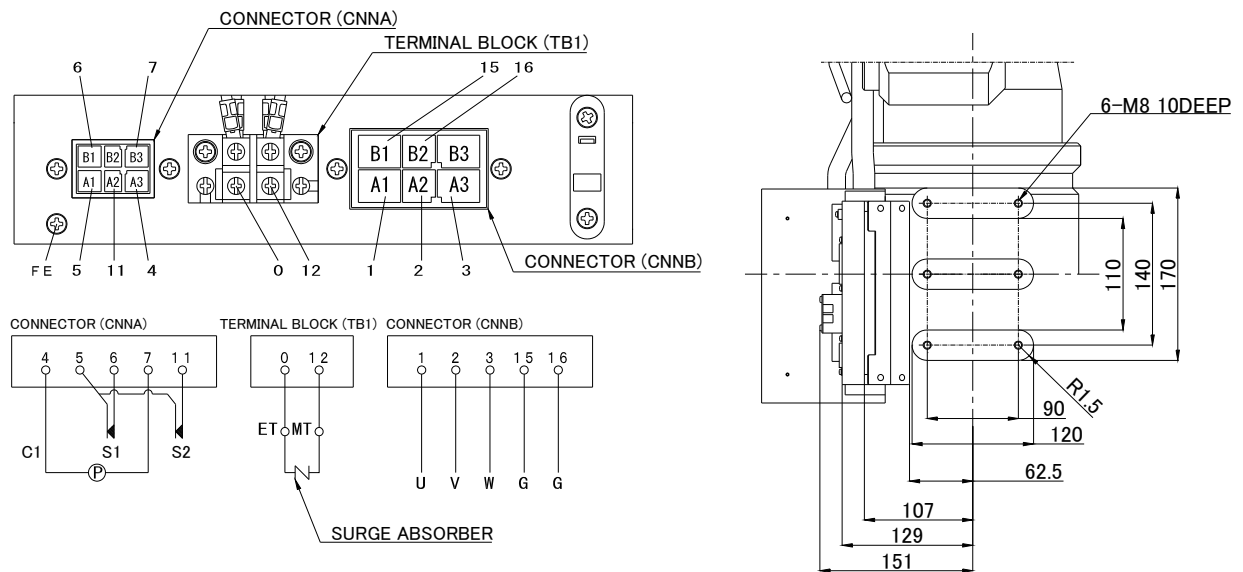

SYMBOL

LOW VOLTAGE TERMINAL

- ETEARTH TERMINAL
- USTATOR U
- VSTATOR V
- WSTATOR W
- GGETTER
- MT.....METAL CENTER TERMINAL

- PPUMP MOTOR (50/60Hz 100V)
- C1TEMPERATURE RELAY COMMON
- S1TEMPERATURE RELAY 80°C (NORMALLY CLOSE)
- S2TEMPERATURE RELAY 70°C (NORMALLY CLOSE)
- FEFUNCTION EARTH TERMINAL



CANON ELECTRON TUBES & DEVICES CO., LTD.

Marketing Engineering Group, Sales Department
1385, Shimoishigami, Otawara-shi, Tochigi 324-8550, Japan
Tel: +81-287-26-6666 Fax: +81-287-26-6060
<https://etd.canon>

·The head office of Canon Electron Tubes & Devices Co., Ltd. has been certified to meet all the requirements of Environmental Management System ISO14001.
·Canon Electron Tubes & Devices Co., Ltd. has been certified to meet all the requirements of Quality Management Systems ISO9001 and ISO13485.
Product scope is referred to the following URL. <https://etd.canon/eng/company/quality.htm>.