

**ROTANODE™
E79036X**

Rotating Anode X-ray Tube Assembly

- ◆ The rotating anode X-ray tube assembly E79036X is designed with Hydrodynamic bearing lubricated by liquid metal and its rotor offers continuous high speed, extra low noise and high reliability.

General Data

IEC Classification (IEC60601-1:2005+A1:2012) Class I ME EQUIPMENT

Electrical:

Circuit:

High Voltage Generator Constant Potential High-voltage Generator
 Grounding Center-grounded

Nominal X-ray Tube Voltage:

Radiographic 125 kV
 Fluoroscopic:
 Continuous 125 kV
 Grid-Control 120 kV

Nominal Focal Spot Value:

Large Focus 0.8
 Small Focus 0.5

Nominal Anode Input Power (at 0.1s) See rating charts

Large Focus 80 kW
 Small Focus 44 kW

Nominal Radiographic Anode Input Power:

Large Focus 80 kW
 Small Focus 44 kW

★The information contained herein is presented only as a guide for the application of our products. No responsibility is assumed by Canon Electron Tubes & Devices Co., Ltd. (CETD) for any infringements of patents or other rights of the third parties which may result from its use. No license is granted by implication or otherwise under any patent or patent rights of CETD or others.
 ★The information contained herein may be changed without prior notice. It is therefore, advisable to contact to CETD before processing with the design of equipment incorporating this product.

Motor Ratings: (Starter: Combination with ST-7017)

Stator: XS-AX

		Starting		Running	
Driven Frequency	[Hz]	165	140	165	140
Input Power	[W]	1500	2300	370	320
Voltage	[V]	220	170	150	125
Current	[A]	12	25 ¹⁾	8	7
Min. Speed Up	[s]	3.5 ²⁾	11.0	-	-
Min. Braking	[s]	3.0 ³⁾	12.0	-	-

Note 1) 25A will be supplied during only 2secnds of starting in boost time.

2) Boost time from idling (Driven Frequency: from 140Hz to 165Hz)

3) Braking time to idling (Driven Frequency: from 160Hz to 140Hz)

Anode Speed	Minimum 9000 min ⁻¹
Cut-off Grid Voltage (Middle, Small Focus)	-2900 VDC
Resistance between Housing and Low Voltage Terminals	Minimum 2 MΩ
Input Voltage of Oil Pump in the Tube Housing	AC 100V, 2A
Heat Exchanger Source Frequency	50/60 Hz
Normal Operating Range of the Housing Temperature	16 ~ 75 °C
Mode of Operation	Intermittent
Envelope Current (125kV/100mA)	(Approx) 10 mA
Envelope Voltage (125kV/100mA)	0 kV

Mechanical:

Dimensions	See dimensional outline
Overall Length	501 mm
Maximum Diameter	175 mm
Target:	
Anode Angle (Effective)	8 degrees
Construction	Rhenium-Tungsten
Permanent Filtration	1.1 mm Al / 75 kV IEC60522:1999
Radiation Protection (In accordance with IEC60601-1-3:2008):	
Leakage Technique Factor	125 kV, 18 mA
X-ray Coverage	230 × 230 at SID 900 mm
Weight (Approx.)	38 kg
High Voltage Receptacle	CLAYMOUNT MINI-75
Cooling Method	Water-Cooled Heat Exchanger
Inner Cooling Method	Oil Circulation
Tube Model Number	E79036
Tube Housing Model Number	XH-1008

Absolute Maximum and Minimum Ratings

(At any time, these values must not be exceeded.)

Maximum X-ray Tube Voltage:	
Radiographic	125 kV
Fluoroscopic	
Continuous	125 kV
Grid-control	120 kV
Between Anode (or Cathode) and Ground	
Radiographic	62.5 kV
Fluoroscopic	
Continuous	62.5 kV
Grid-control	60 kV
Minimum X-ray Tube Voltage	50 kV
Maximum X-ray Tube Current: (See rating charts)	
Large Focus	800 mA
Small Focus	470 mA
Maximum Filament Current:	
Large Focus	5.9 A
Small Focus	5.2 A
Filament Voltage: (At maximum filament current)	
Large Focus (5.9 A)	13.2 ~ 17.8 V
Small Focus (5.2 A)	11.5 ~ 15.5 V
Filament Frequency Limits	0 ~ 25 kHz
Continuous Anode Input Power	2200 W (3100 HU/s)
Thermal Characteristics:	
Anode Heat Content	1500 kJ (2100 kHU)
Maximum Anode Heat Dissipation	4500 W (6300 HU/s)
X-ray Tube Assembly Heat Content	1900 kJ (2679 kHU)
Nominal Continuous Input Power:	
With Water-Cooled Heat Exchanger (HEX-125)	3000 W (254 kHU/min)

Environmental Limits

Operating Limits:

Temperature	18 ~ 40 °C
Relative Humidity	30 ~ 85 %
	(No condensation)
Atmospheric Pressure	70 ~ 106 kPa

Transport and Storage:

Temperature:

With Cooling Water Empty	-20 ~ 70 °C
With Cooling Water Filled	2 ~ 60 °C
Relative Humidity	20 ~ 90 %
	(No condensation)
Atmospheric Pressure	50 ~ 106 kPa

Position Cathode under

Note 1) Please drain coolant off from X-ray tube assembly during transportation, storage and etc.
Otherwise, the X-ray tube assembly might be damaged by freeze of coolant.

Absolute Maximum Rating Charts

Conditions: Tube Voltage
 Constant Potential High-voltage Generator
 Anode Rotation Speed 9000min⁻¹

Nominal Focal Spot Value: 0.8 ■

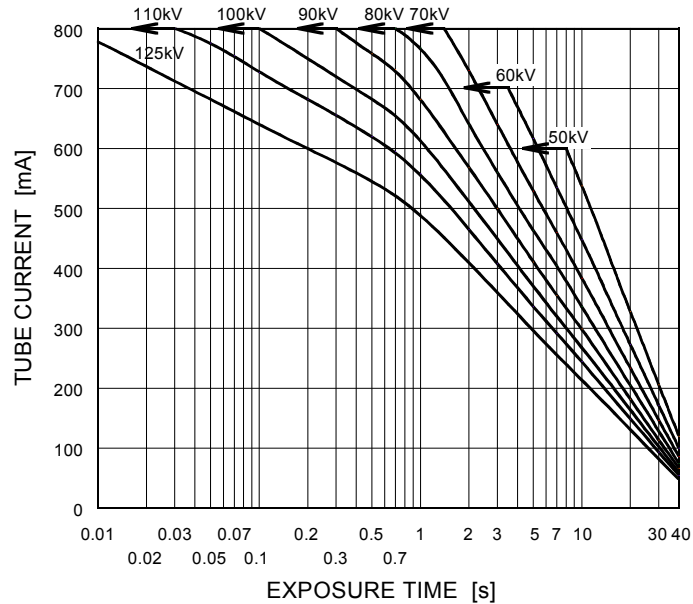

Do not exceed values in above table at all the time.
 Equipment setting and calibration errors must be considered not to exceed the table values.

Nominal Focal Spot Value: 0.5 □

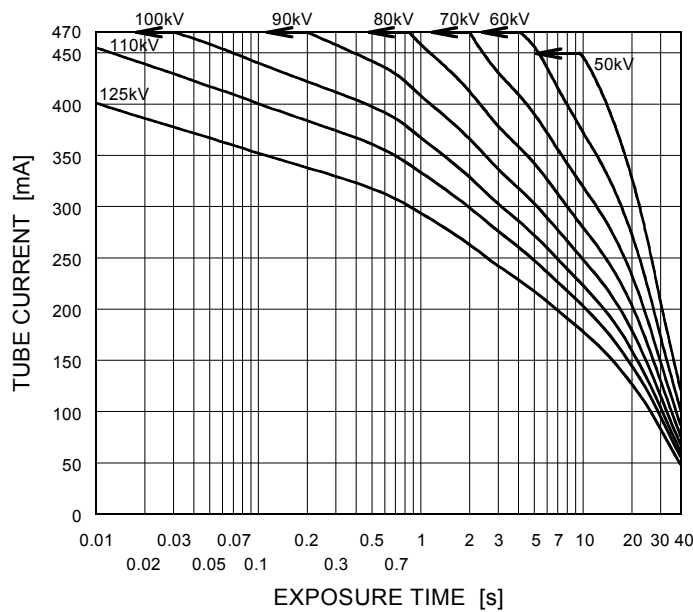

Do not exceed values in above table at all the time.
 Equipment setting and calibration errors must be considered not to exceed the table values.

Cine-fluorographic Rating Charts

Conditions: Constant Potential High-voltage Generator
 Anode Rotation Speed 9000min⁻¹

Nominal Focal Spot Value: 0.8 ■

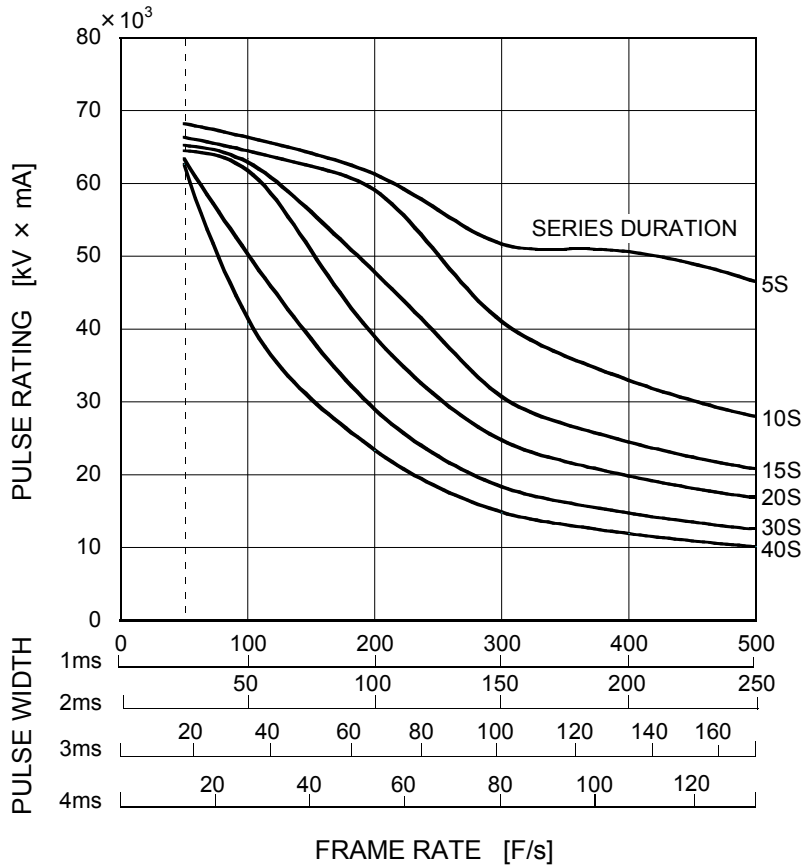

Do not exceed values in above table at all the time.
 Equipment setting and calibration errors must be considered not to exceed the table values.

Cine-fluorographic Rating Charts

Conditions: Constant Potential High-voltage Generator
Anode Rotation Speed 9000min^{-1}

Nominal Focal Spot Value: 0.5 \blacksquare

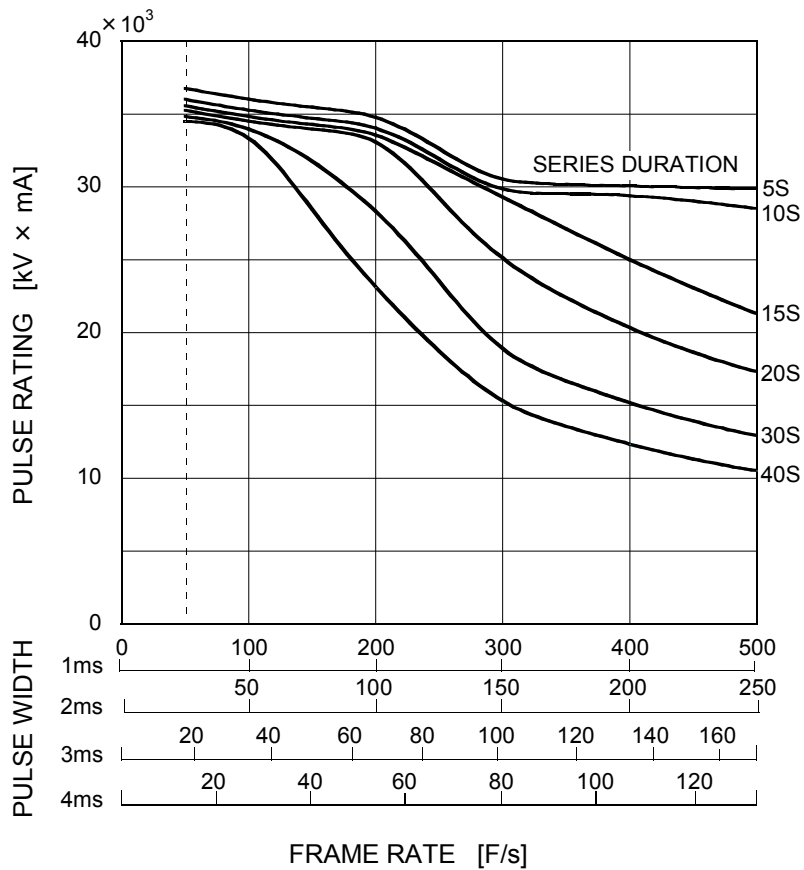

Do not exceed values in above table at all the time.
Equipment setting and calibration errors must be considered not to exceed the table values.

Emission & Filament Characteristics (Typical Value)

Constant Potential High-voltage Generator

Nominal Focal Spot Value: 0.8 ■

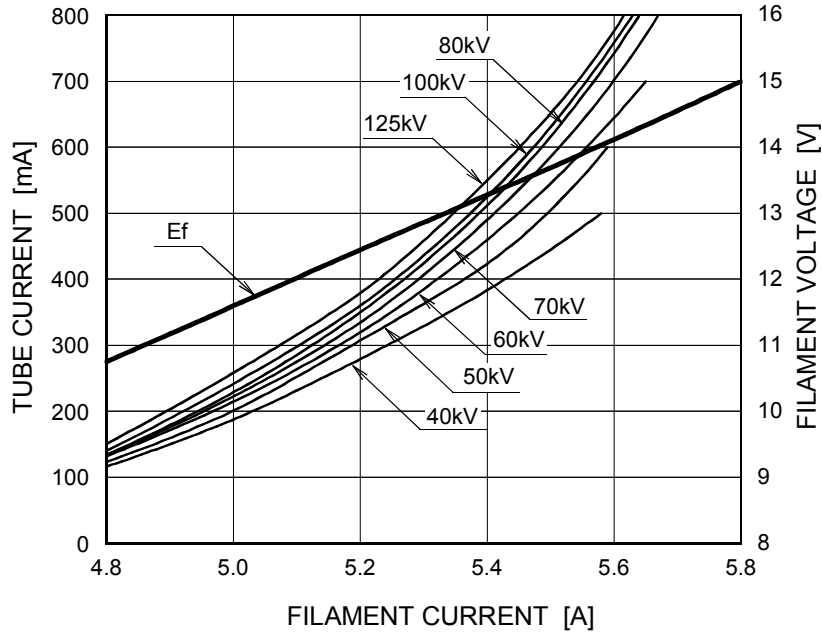

For Reference Only

Nominal Focal Spot Value: 0.5 □

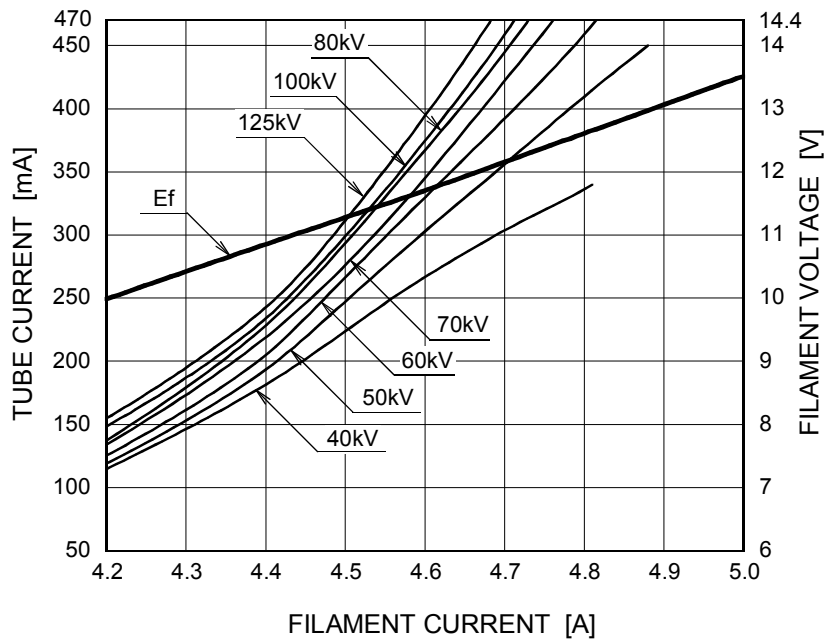

For Reference Only

Thermal Characteristics

X-ray Tube Assembly Heating / Cooling Curve
(Environmental Temperature: 25°C)

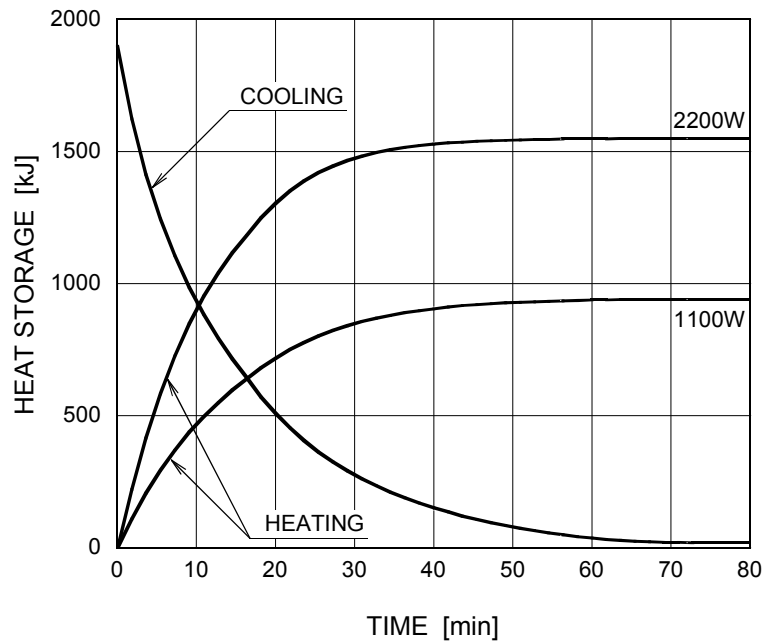

Anode Heating / Cooling Curve

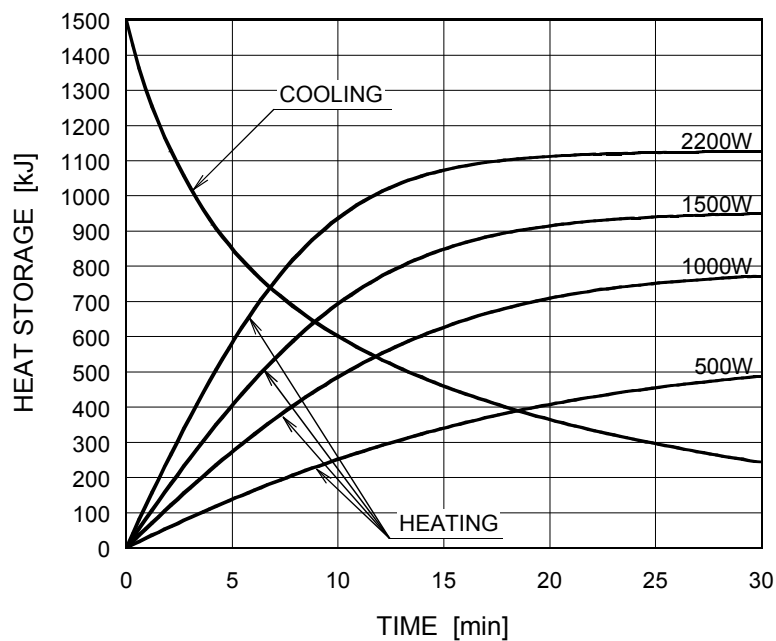

Dimensional Outline (1)

Unit: mm

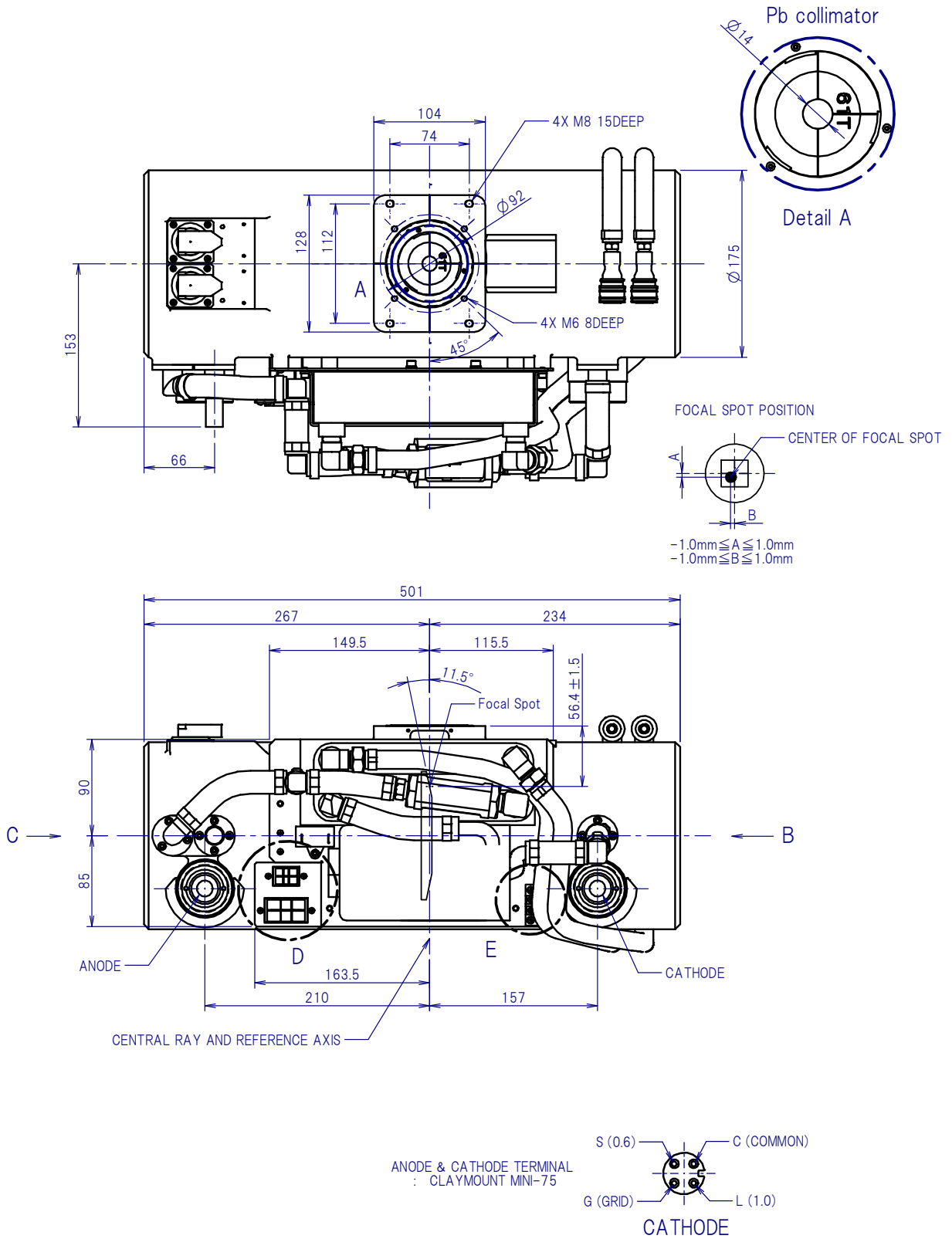

Dimensional Outline (2)

Unit: mm

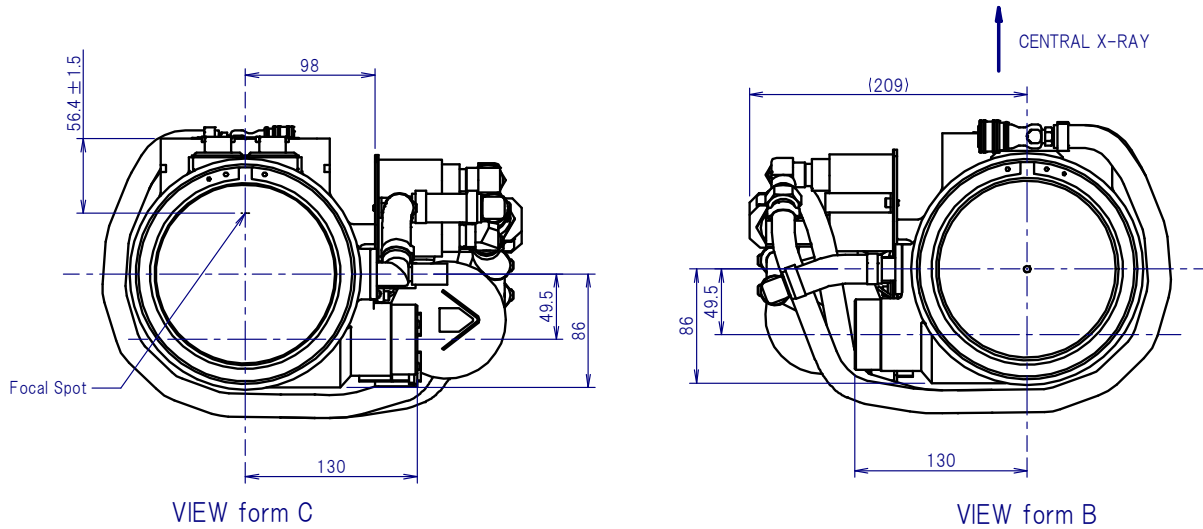

LOW VOLTAGE WIRING DIAGRAM PORT TERMINAL CONFIGURATION

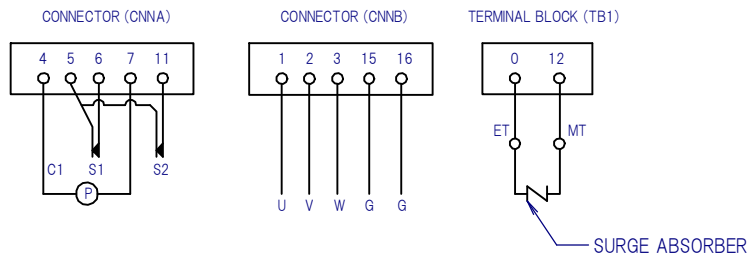
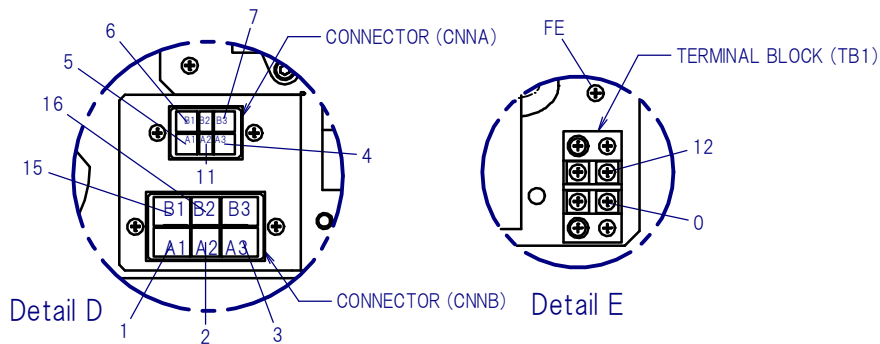

SYMBOL
 LOW VOLTAGE TERMINAL
 ET.....EARTH TERMINAL
 USTARTOR U
 VSTARTOR V
 WSTARTOR W
 GGETTER
 MT.....METAL CENTER TERMINAL

PPUMP MOTOR (50/60Hz 100V)
 C1.....TEMPERATURE RELAY COMMON
 S1.....TEMPERATURE RELAY 80°C(NORMALLY CLOSE)
 S2.....TEMPERATURE RELAY 70°C(NORMALLY CLOSE)
 FE.....FUNCTION EARTH TERMINAL



CANON ELECTRON TUBES & DEVICES CO., LTD.

Marketing Engineering Group, Sales Department
1385, Shimoishigami, Otawara-shi, Tochigi 324-8550, Japan
Tel: +81-287-26-6666 Fax: +81-287-26-6060
<https://etd.canon>

·The head office of Canon Electron Tubes & Devices Co., Ltd. has been certified to meet all the requirements of Environmental Management System ISO14001.
·Canon Electron Tubes & Devices Co., Ltd. has been certified to meet all the requirements of Quality Management Systems ISO9001 and ISO13485.
Product scope is referred to the following URL. <https://etd.canon/eng/company/quality.htm>.